

未注公差/General tolerances(mm)												0.1/10	
0	>3	>6	>10	>18	>30	>50	>80	>120	>180	>250	>315		>400
~3	~6	~10	~18	~30	~50	~80	~120	~180	~250	~315	~400	~500	>500
±0.12	±0.18	±0.22	±0.26	±0.31	±0.37	±0.57	±0.80	±0.93	±1.05	±1.15	±1.60	±2.20	±2.50

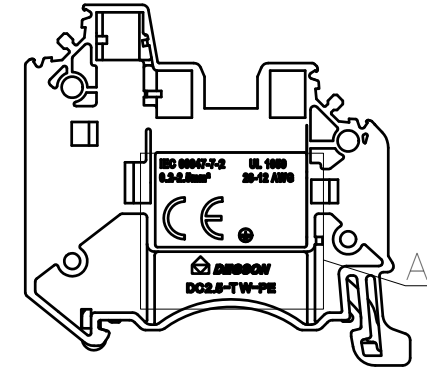
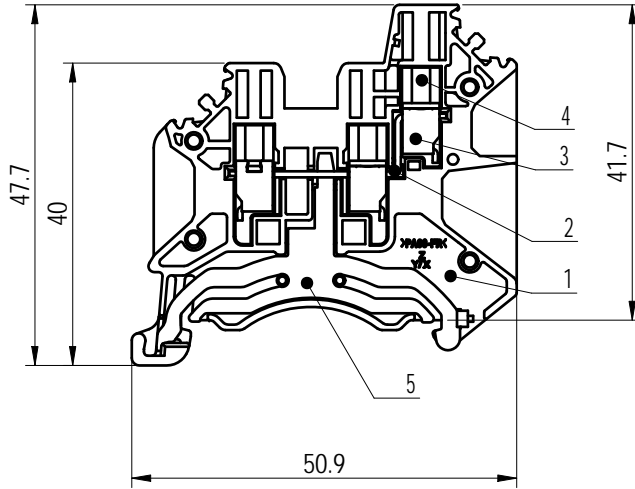

ITEM	NAME OF PART	MATERIAL	NOTES
5	Grounding	Copper alloy	Sn Plated
4	Screw	Steel	M2.5\Zn Plated
3	Cage	Steel	Zn Plated
2	Current carrier	Copper	Sn Plated
1	Housing	PA66	UL94V-0

A
2:1

Please refer to the 3D model for those unmarked dimensions

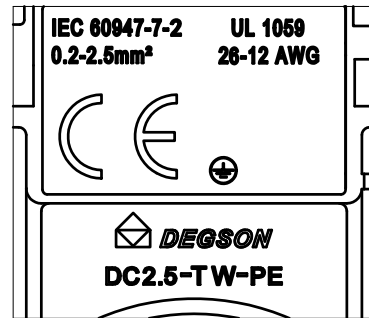
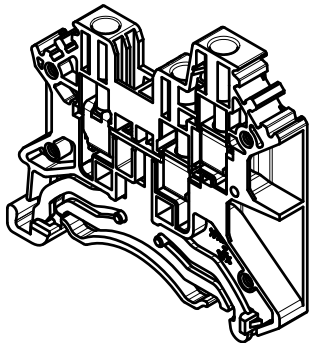

UL 标准/UL Standard:	B	C	D
额定电压/电流/Rated Voltage(V)/Current(A)	/	/	/
IEC 标准/IEC Standard:			
过压类别/Overvoltage Category/污染等级/Pollution Degree	III/3	III/2	II/2
额定电压/电流/Rated Voltage(V)/Current(A)	/	/	/
额定脉冲电压(KV)/Rate Impulse Voltage(KV)	/	/	/
螺丝扭矩/Torque Tightening(N·m/Lb.in)	M2.5: 0.4/3.6		
线径范围(硬线和软线)/Wire Range(rigid and flexible)(AWG/mm²)	26~12 / 0.2~2.5,4sol		
间距/Pitch(mm)/线数范围/Poles	5.2/01P		
剥线长度/Stripping length(mm)	9~10		
使用温度范围/Operating temperature(°C)	-40~+105		
符合 RoHS 环保要求/Conform to RoHS	Yes		
标准颜色编号/Standard color number: PANTONE / RAL	/		

DEGSON		MATERIAL:	SURFACE/COLOR:	
APPD: 李根芳	2022.04.27	MAT NO./REV: 11020000239-1 / 00	MAT STATUS: 样品	
CHKD: 马恩开	2022.04.26	NAME: DC2.5-TW-PE-01P-1C-00A(H)		
DRFT: 刘承博	2022.04.26	DRAWING NO. 200067734	TYPE: CUSTOMER DRAWING	DRAWING STATUS: SCALE: 2:1 SHEET: 1/1

REV	ECN	DESCRIPTION	DRFT	DATE
01		NEW DRAWING	刘承博	2022.04.26

Transfer or duplication of this document as well as the utilization or communication of its contents are prohibited unless written authorization is granted. Degson will be liable for compensation. All rights reserved for patent, utility model or design registrations. 非经书面明确授权, 否则禁止转让、复制、利用、交加本文件的内容, 一经发现将负法律责任, 一经发现保留对涉及发明、实用新型和外观设计的所有权利。