

Transfer or duplication of this document as well as the utilization or communication of its contents are prohibited unless explicit authorization is granted. Violations will be liable for compensation. All rights reserved for patent, utility, model or designs registrations. 除非给予明确授权，否则禁止转让、复制、利用、交寄本文件的内容。未经许可擅自复制或传播，侵犯者将承担法律责任。本公司保留对涉及发明、实用新型和外观设计的所有权利。

未注公差/General tolerances(mm)											D 0.1/10		
0	>3	>6	>10	>18	>30	>50	>80	>120	>180	>250		>315	>400
~3	~6	~10	~18	~30	~50	~80	~120	~180	~250	~315	~400	~500	~2'
±0.12	±0.18	±0.22	±0.26	±0.31	±0.37	±0.57	±0.80	±0.93	±1.05	±1.15	±1.60	±2.20	±2.50

JL 标准/UL Standard:	B	C	D
额定电压/电流/Rated Voltage(V)/Current(A)	600/30	600/30	/
IEC 标准/IEC Standard:			
过压类别/Overvoltage Category/污染等级/Pollution Degree	III/3	III/2	II/2
额定电压/电流/Rated Voltage(V)/Current(A)	1000/32	/	/
额定脉冲电压(KV)/Rate Impulse Voltage(KV)	8.0	/	/
螺丝扭矩/Torque Tightening(N·m/Lb.in)	M3, 0.65/6		
线径范围(硬线和软线)/Wire Range(rigid and flexible)(AWG/mm ²)	22~10/0.5~4		
剥线长度/Stripping length(mm)	8~9		
使用温度范围/Operating temperature(°C)	-40~+105		
符合RoHS环保要求/Conform to RoHS	Yes		

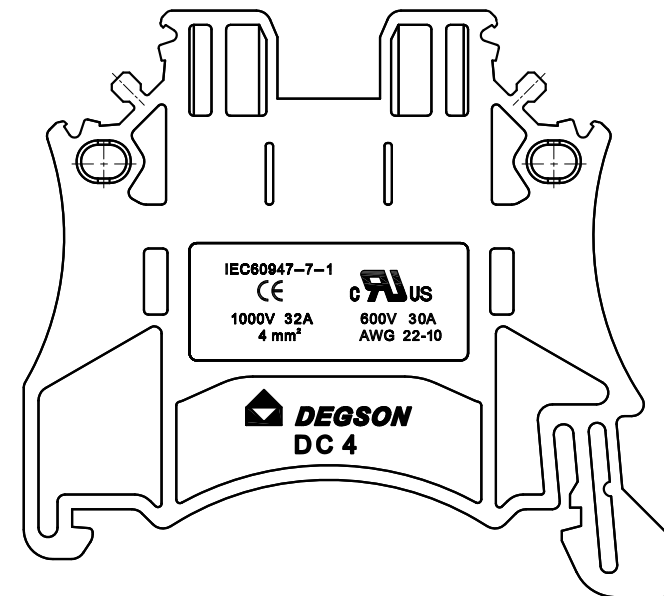
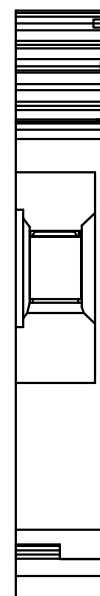
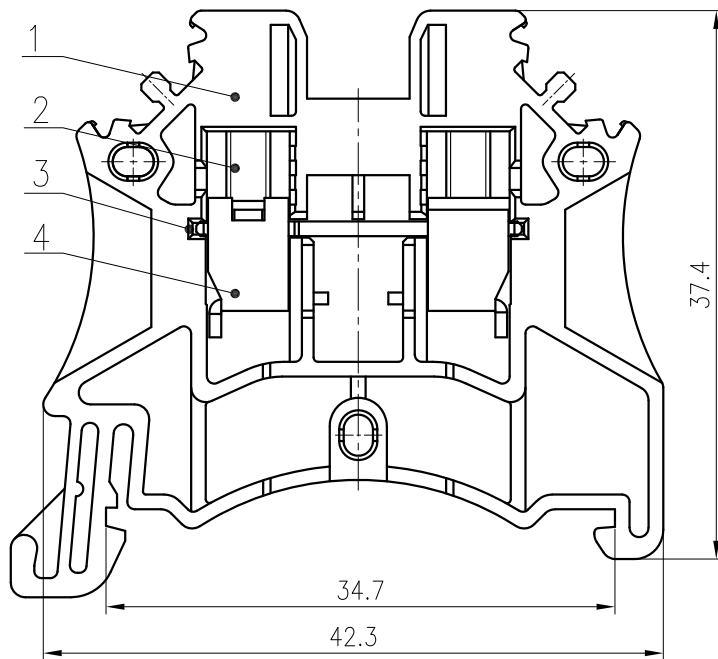
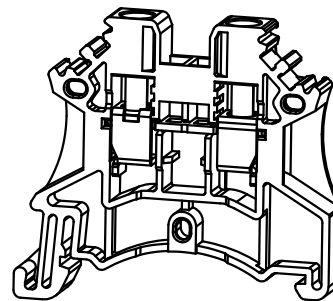
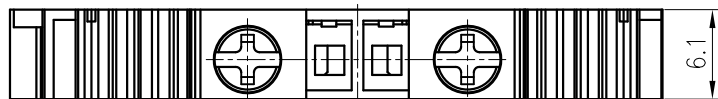

4	Cage	Steel	M3/Zn Plated
3	Current carrier	Copper	Sn Plated
2	Screw	Steel	M3/Zn Plated
1	Housing	PA66	UL94V-0
ITEM	NAME OF PART	MATERIAL	NOTES

REV	ECN	DESCRIPTION	DRFT	DATE

MATERIAL:	/	SURFACE:	/
MAT NO.:			
STATUS:	/		
APPD: Lan ChH 2020.12.03	NAME: 宁波高松电子有限公司 NINGBO DEGSON ELECTRICAL CO., LTD		
CHKD: Yu JZh 2020.12.03	DC4-01P-1Y-12A(H)		
DRFT: ChenZh 2020.07.13	DRAWING NO.:	11000368	REV TO
	TYPE: CUSTOMER DRAWING	SCALE: 2:1	SHEET 1/1