

Transfer or duplication of this document as well as the utilization or communication of its contents are prohibited unless explicit authorization is granted. Violations will be liable for compensation. All rights reserved for patent, utility, model or designs registrations. 除非给予明确授权，否则禁止转让、复制、利用、交易本文件的内容。未经许可擅自复制或传播，使用者将承担法律责任。本公司保留对专利和商标的所有权利。

Please refer to the 3D model, for these unmarked dimensions.

未注公差/General tolerances(mm)										0.1/10			
0	>3	>6	>10	>18	>30	>50	>80	>120	>180		>250	>315	>400
~3	~6	~10	~18	~30	~50	~80	~120	~180	~250	~315	~400	~500	>500
±0.12	±0.18	±0.22	±0.26	±0.31	±0.37	±0.57	±0.80	±0.93	±1.05	±1.15	±1.60	±2.20	±2.50

JL 标准/UL Standard:	B	C	D
额定电压/电流/Rated Voltage(V)/Current(A)	/	/	/
IEC 标准/IEC Standard:			
过压类别/Overvoltage Category/污染等级/Pollution Degree	III/3	III/2	II/2
额定电压/电流/Rated Voltage(V)/Current(A)	/	/	/
额定脉冲电压(KV)/Rate Impulse Voltage(KV)	6.0	/	/
螺丝扭矩/Torque Tightening(N·m/Lb.in)	M3, 0.65/6.0		
线径范围(硬线和软线)/Wire Range(rigid and flexible)(mm ² /AWG)	0.5~4/22~10		
间距/Pitch(mm)/线数范围/Poles	6.20/01P		
剥线长度/Stripping length(mm)	8~9		
使用温度范围/Operating temperature(°C)	-40~+105		
符合RoHS环保要求/Conform to RoHS	Yes		
标准颜色编号/Standard color number: PANTONE / RAL	/		

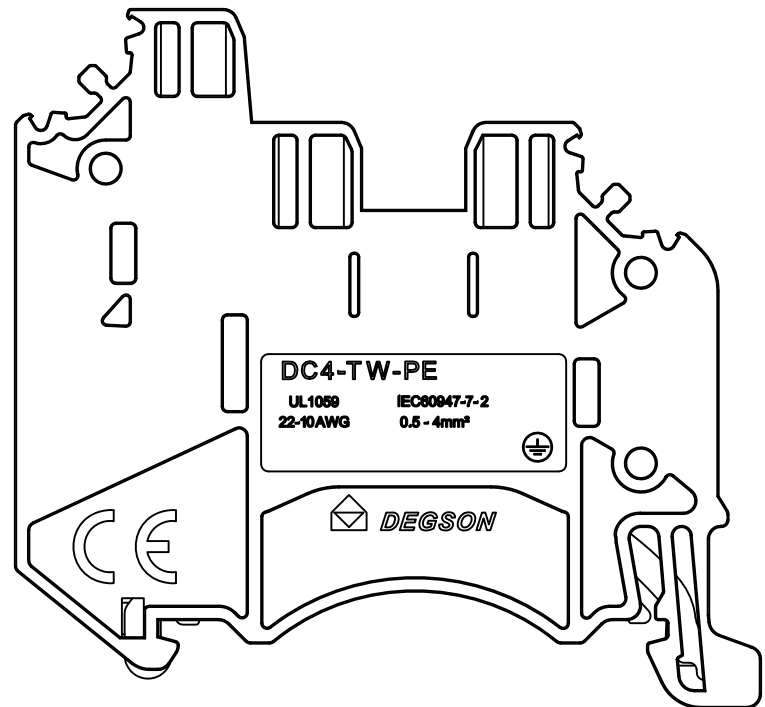
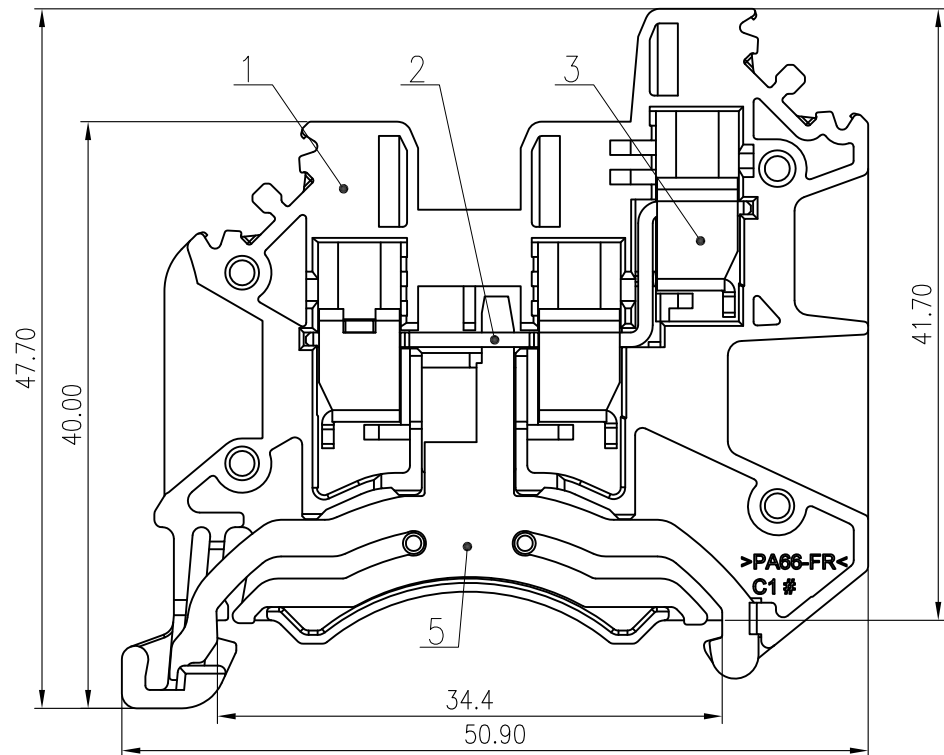
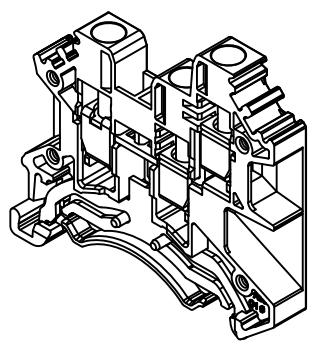
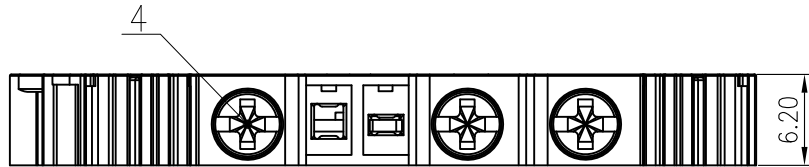

5	Grounding body	Copper alloy	Sn Plated
4	Screw	Steel	M3/Zn Plated
3	Cage	Steel	M3/Zn Plated
2	Current carrier	Copper	Sn Plated
1	Housing	PA66	UL94V-0
ITEM	NAME OF PART	MATERIAL	NOTES

MATERIAL:	/	SURFACE:	/
MAT NO.:		宁波高松电子有限公司 NINGBO DEGSON ELECTRICAL CO., LTD	
STATUS:	/		
APPD: Li GL 2022.03.04	NAME:	DC4-TW-PE-01P-1C-00A(H)	
CHKD: Ma EK 2022.03.04	DRAWING NO.:	/	REV D0-1
DRFT: Mi Sh 2022.03.04	TYPE: CUSTOMER DRAWING	SCALE: 2:1	SHEET 1/1